

Power Max Series
Large Dimension Mono Solar Module

SR-M660L SR-M660310L
SR-M660315L
310~325W SR-M660320L
SR-M660325L

IEC61215/IEC61730
ISO9001:Quality Management System ISO14001:Environmental Management System
ISO45001:Occupational Health and Safety Management System



PID Resistance



5 Bus Bar solar Cell
With PERC Technology



High Power Output



Strengthened Mechanical
Support 5400 Pa Snow
Load, 2400 Pa Wind Load



0~3% Positive Tolerance



Better Low-light
Performance

Additional value from SUNRISE linear warranty

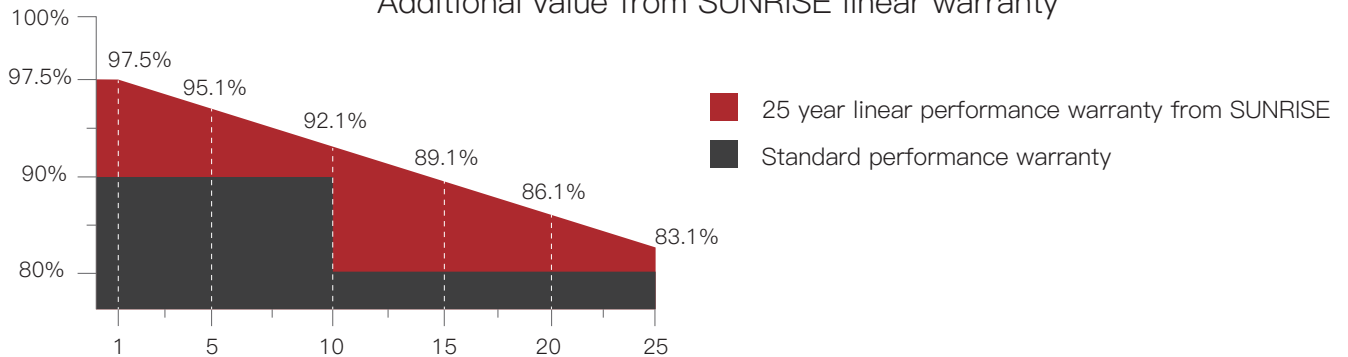

Module Type		SR-M660310L		SR-M660315L		SR-M660320L		SR-M660325L	
Test Environment		STC	NOCT	STC	NOCT	STC	NOCT	STC	NOCT
Tolerance	(%)	0~+3		0~+3		0~+3		0~+3	
Module Efficiency	(%)	18.59		18.88		19.18		19.48	
Maximum Power	Pmax(W)	310	232	315	237	320	240	325	243
Open Circuit Voltage	Voc(V)	40.39	37.42	40.64	37.59	40.88	37.82	41.12	38.1
Short Circuit Current	Isc(A)	9.9	8.26	10.06	8.35	10.15	8.43	10.19	8.5
Maximum Power Voltage	Vm(V)	33.01	31.06	33.21	31.23	33.41	31.42	33.61	31.62
Maximum Power Current	Im(A)	9.4	7.46	9.49	7.53	9.58	7.61	9.67	7.67
Cell Type	(mm)	158.75×158.75(Mono-Crystalline Silicon)							
Number of Cells	(Pcs)	60(6×10)							
Maximum System Voltage	(V)	DC1000/DC1500							
Temp. Coeff. of Voc	(%/°C)	-0.282							
Temp. Coeff. of Isc	(%/°C)	0.041							
Temp. Coeff. of Pm	(%/°C)	-0.387							
Operating Temperature	°C	-40 to 85							
Nominal Operating Cell Temperature (NOCT)	°C	45±2							
Max. Series Fuse	(A)	15/20							
Pressure Bearing	(Pa)	5400							
Wind Bearing	(Pa)	2400							

STC: Irradiance 1000W/m², Cell temperature 25°C, AM1.5

NOCT: Irradiance 800W/m², Ambient temperature 20°C, Wind speed 1m/s

ENGINEERING DRAWINGS

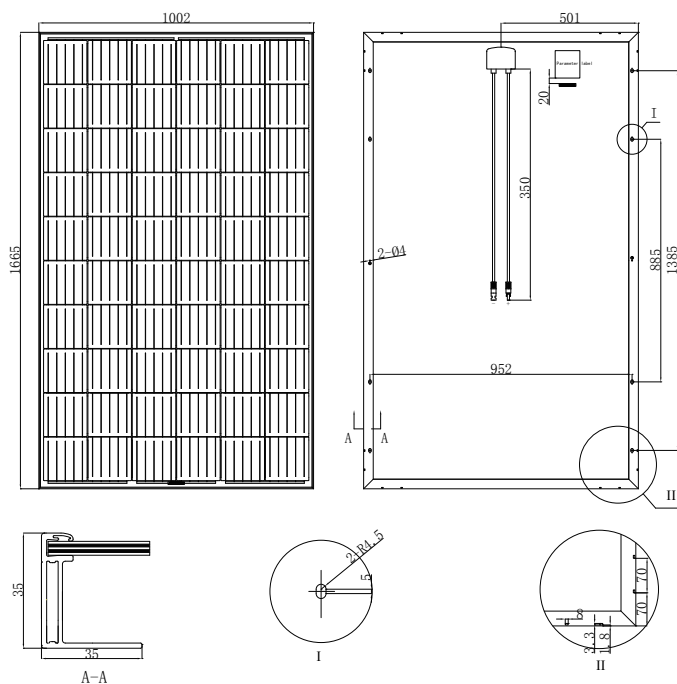

Manufactured in China

MATERIAL DETAILS

Frame	Anodized aluminum
Glass	3.2mm low-iron tempered suede glass
Cell	6×10 pcs 158.75mm mono solar cell
Junction Box	Rated Current ≥ 15A, IP ≥ 68, TÜV & UL
Diode quantity	3
Cable&Connector	4mm ² , MC4 or MC4 compatible 4mm ² , EVO2 or EVO2 compatible
Cable length	350mm or as customer's requirements

IV CURVES

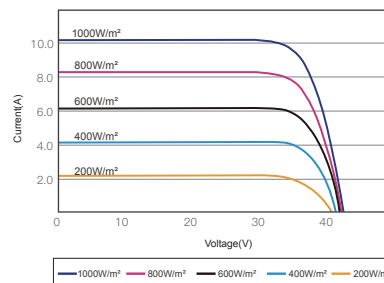

I-V CURVES OF PV MODULE(320W)

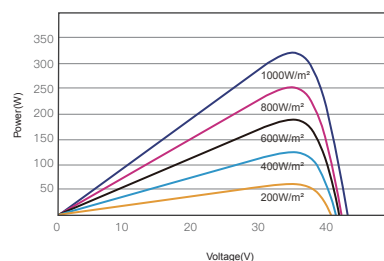

P-V CURVES OF PV MODULE(320W)

PACKING DETAILS

Dimension	(mm)	1665×1002×35
Weight	(kg)	19
Loading Capacity		348 pcs / 20'GP 924 pcs / 40'HC
Packing	pcs/pallet	30